

WM-104 WM-204

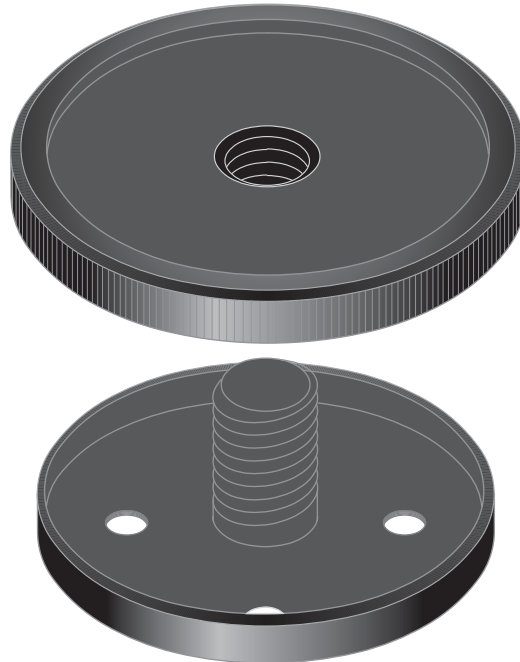

ACCESORIO FIJACION MICROFONO
ACCESSOIRE FIXATION MICROPHONE
MICROPHONE ATTACHMENT ACCESORY



EJEMPLOS DE MONTAJE
EXEMPLES DE MONTAGE
ASSEMBLY EXAMPLES

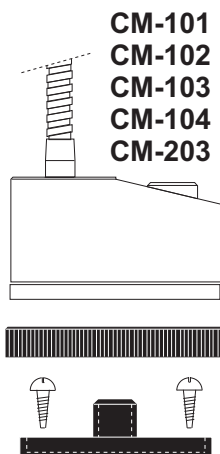

WM-104
WM-204

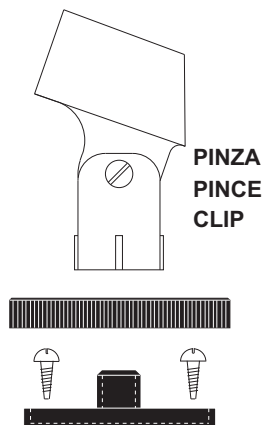

WM-104
WM-204

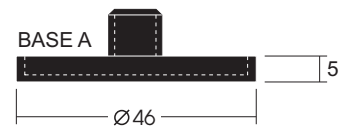
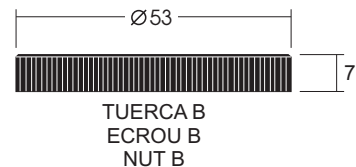

MEDIDAS EN MILIMETROS
 PESO= 95 Gr.
 COLOR = WM-104: Negro
 WM-204: Blanco

MESURES EN MILLIMETRES
 POIDS= 95 g.
 COULEUR = WM-104: Noir
 WM-204: Blanc

MEASUREMENTS IN MILLIMETRES
 WEIGHT= 95 g.
 COLOUR = WM-104: Black
 WM-204: White

Electroacústica



www.udeaudio.com

Central Avda. BARCELONA, 24
 08970 - SANT JOAN DESPÍ
 BARCELONA - ESPAÑA
 Tel: 34-93 477 28 54
 Fax: 34-93 261 17 52
ude@udeaudio.com

Delegación C/ LUIS I, 60, portal 4-B, 3ª planta
 Madrid 28031 - MADRID
 ESPAÑA
 Tel: 34-91 311 60 76
 Fax: 34-91 450 19 97
centro@udeaudio.com

ISO 9001
 BUREAU VERITAS
 Certification



Se reserva el derecho de variar las características técnicas de sus productos sin previo aviso

610.040CFA | 1 / 2

INSTRUCCIONES DE MONTAJE

- 1.- Fijar la base A mediante 3 tornillos. (Fig. 1)
- 2.- Enroscar la tuerca B a fondo. (Fig. 2)
- 3.- Enroscar suavemente el micrófono o la pinza a fondo. (Fig. 3)
- 4.- Desenroscar hasta conseguir la orientación deseada. (Fig. 4)
- 5.- Fijar mediante B a contratuerca. (Fig. 5)

INSTRUCTIONS DE MONTAGE

- 1.- Fixer la base A à l'aide des 3 vis. (Fig. 1)
- 2.- Visser l'écrou B à fond. (Fig. 2)
- 3.- Visser doucement le microphone ou la pince à fond. (Fig. 3)
- 4.- Dévisser jusqu'à ce qu'on obtienne l'orientation souhaitée. (Fig. 4)
- 5.- Fixer à l'aide de B sur le contre-écrou. (Fig. 5)

ASSEMBLY INSTRUCTIONS

- 1.- Attach base A using the 3 screws (Fig. 1)
- 2.- Screw nut B down tightly (Fig. 2)
- 3.- Screw the microphone on gently or the clip fully (Fig. 3)
- 4.- Unscrew until you get the direction you wish (Fig. 4)
- 5.- Fix to the backnut using B (Fig. 5)

Fig. 1

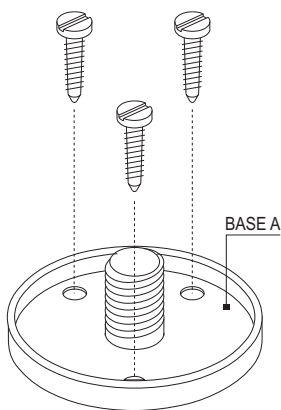

Fig. 2

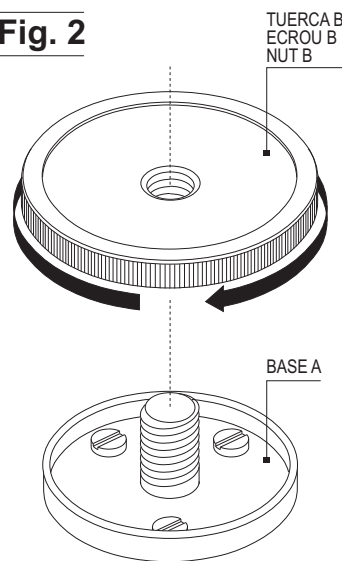

Fig. 3

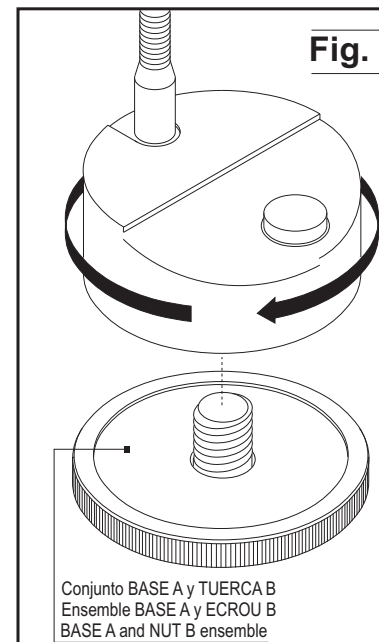

Fig. 4

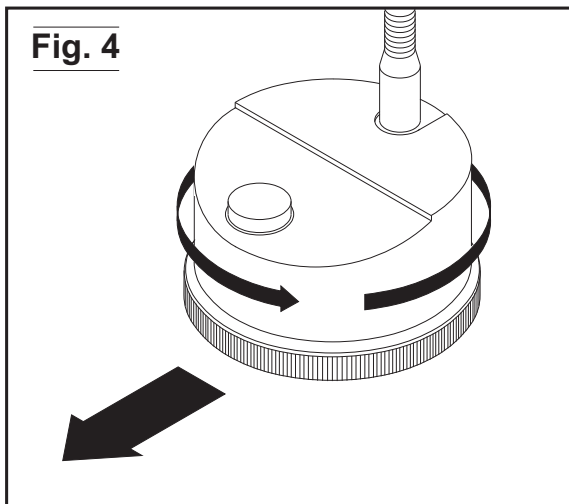

Fig. 5

