

# WM-102 WM-202

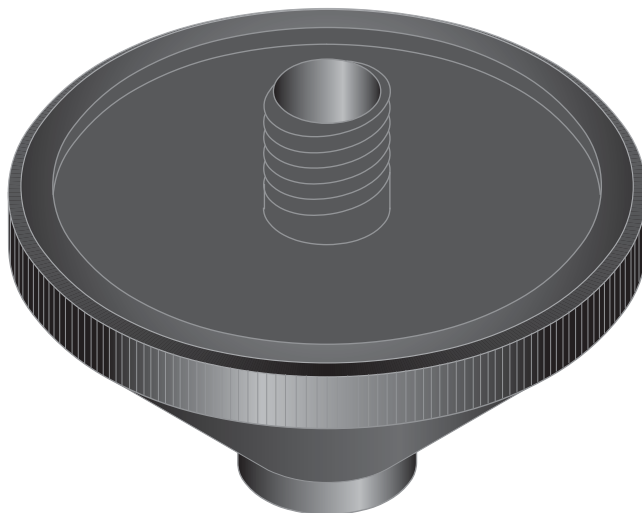

ADAPTADOR MICROFONO  
ADAPTEUR MICROPHONE  
MICROPHONE ADAPTER



## EJEMPLO DE MONTAJE EXEMPLE DE MONTAGE ASSEMBLY EXAMPLE

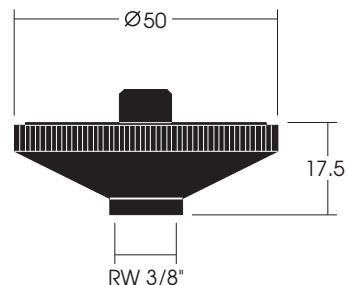
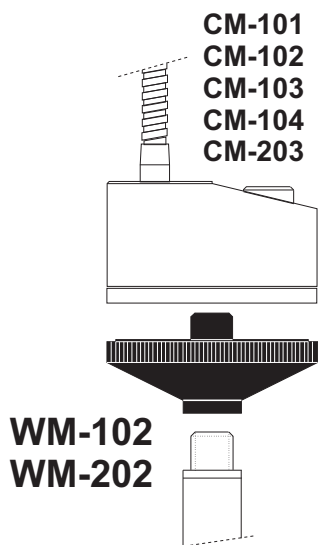

MEDIDAS EN MILIMETROS  
PESO =150 Gr.  
COLOR = WM-102: Negro  
WM-202: Blanco

MESURES EN MILLIMETRES  
POIDS =150 g.  
COULEUR = WM-102: Noir  
WM-202: Blanc

MEASUREMENTS IN MILLIMETRES  
WEIGHT =150 g.  
COLOUR = WM-102: Black  
WM-202: White

Electroacústica

 **UNION  
DESARROLLOS  
ELECTRONICOS s.a.**

[www.udeaudio.com](http://www.udeaudio.com)

Central Avda. BARCELONA, 24  
08970 - SANT JOAN DESPÍ  
BARCELONA - ESPAÑA  
Tel: 34-93 477 28 54  
Fax: 34-93 261 17 52  
[ude@udeaudio.com](mailto:ude@udeaudio.com)

Delegación C/ LUIS I, 60, portal 4-B, 3ª planta  
Madrid 28031 - MADRID  
ESPAÑA  
Tel: 34-91 311 60 76  
Fax: 34-91 450 19 97  
[centro@udeaudio.com](mailto:centro@udeaudio.com)

ISO 9001  
BUREAU VERITAS  
Certification



Se reserva el derecho de variar las características técnicas de sus productos sin previo aviso

610.038CFA | 1 / 1