

# CM-104

## MICROPHONE

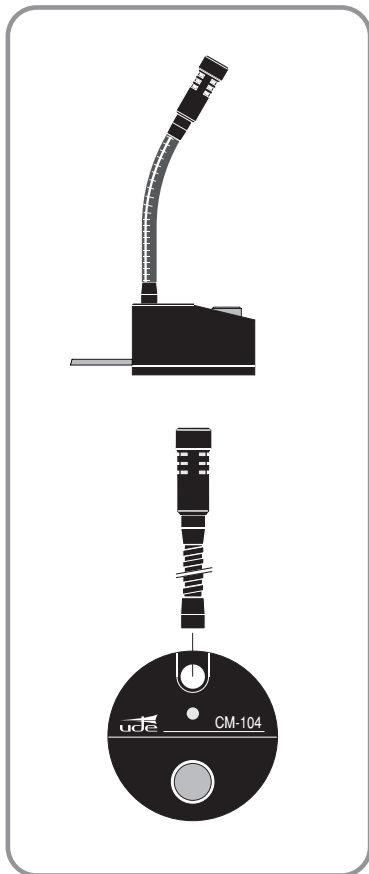

Universal presidential microphone, miniature, with flex, switch and on/off light. Balanced output signal using cable and XLR connector.



### TECHNICAL FEATURES

- Transducer:	Prepolarised condenser.	- Built-in signal switch.	
- Directionality:	Supercardioid (one-way).	- On/off light.	
- Sensitivity:	-62 dB (0 dB=1 V/ $\mu$ Bar).	- Presentation:	Epoxy metal.
- Impedance:	400 ohm.	- Colour:	Black.
- Output:	Balanced.	- Weight:	260 grammes.
- Maximum permitted level:	115 dB NPS.	- Dimensions:	Base = $\varnothing$ 50x29 mm.
- Power supply:	Phantom (9 to 48 VDC.).		Flex = 122 mm.

Electroacústica

 **UNION  
DESARROLLOS  
ELECTRONICOS s.a.**

[www.udeaudio.com](http://www.udeaudio.com)

**Main Office** Avda. BARCELONA, 24  
08970 - SANT JOAN DESPÍ  
BARCELONA - ESPAÑA  
Tel: 34-93 477 28 54  
Fax: 34-93 261 17 52  
[ude@udeaudio.com](mailto:ude@udeaudio.com)

**Madrid Delegation** C/ LUIS I, 88, 3ª planta  
28031 - MADRID  
ESPAÑA  
Tel: 34-91 311 60 76  
Fax: 34-91 450 19 97  
[centro@udeaudio.com](mailto:centro@udeaudio.com)

ISO 9001  
BUREAU VERITAS  
Certification



UDE reserves the right to modify the technical characteristics of its products without previous notice

610.179A | 1 / 2

## DESCRIPTION

The UDE CM-100 family of microphones includes the CM-104 model with a 122 mm. flex.

Designed for:

- Applications which requires that orator face should not have to be masked by the microphone.
- For architectural or aesthetic considerations.

The CM-104 microphone includes one cell to a prepolarised condenser, and has been designed specifically for voice reproduction.

Its supercardioid polar diagram reduces environmental noise pick-up, thereby enhancing the speaker's voice. It also reduces acoustic coupling (Larsen effect). The result can be even further enhanced when used with a WX-19 diagram (anti-Larsen).

Its attractive streamlined and functional design makes it suitable for applications requiring a combination of aesthetic appeal and high-performance technology, such as:

- Conference halls
- Temples
- Administration, etc.

The CM-104 microphone has a built-in pre-amplifier which is remote-powered from the amplifier (Phantom power), which means it requires no batteries.

It is protected against external R.F. interference, electrostatic and magnetic fields.

Its output signal is balanced, allowing the use of a microphone with long cable lengths without any noise pick up or appreciable signal losses.

The CM-104 has an on/off switch and light.

It is supplied with a foam filter and case.

## USE

Its modular design makes it universal for different applications, using the following accessories:

- **Desktop assembly:** Fit **WM-103** base (optional)
- **Fixed assembly on Lectern, Ambo or Table:** Adapter coupler **WM-104** (optional)
- **Assembly with telescopic stand:** Adapter coupler **WM-102** (optional)
- **Foam filter:** Should be used when the speaker is speaking close to the microphone.

## OPTIONAL ACCESSORIES

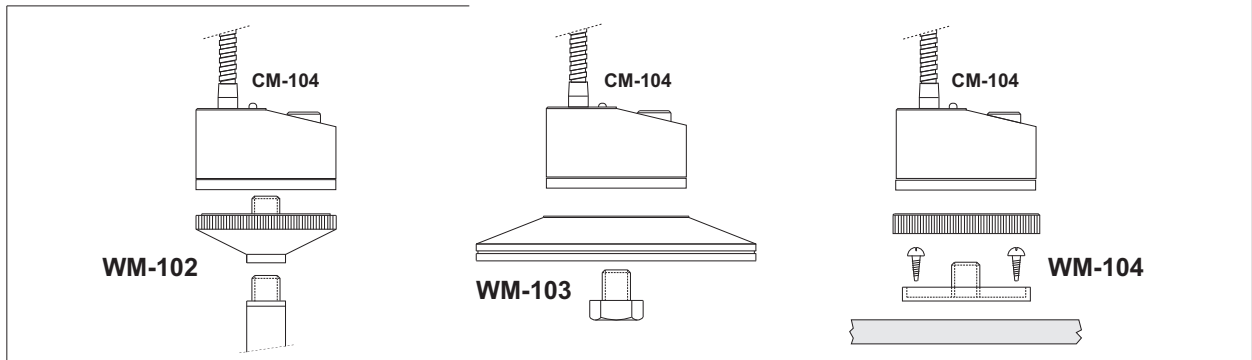

## WIRING

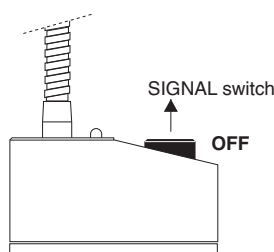
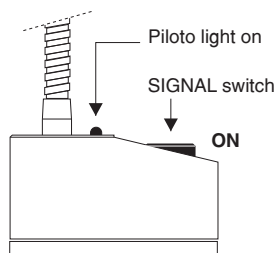

### XLR CONNECTOR

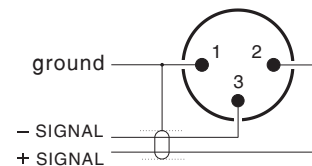

### IMPORTANT:

To connect the CM-103 microphone to a UDE apparatus, connect the programme jumpers for "Phantom" power. These are included inside the amplifier (AXD-129, AXD-249, AX-309, AX-129, AX-109, AX-59, AX-29, PXD-59, PX-9).

Please contact us for other makes and models.