

CM-101

MICROPHONE

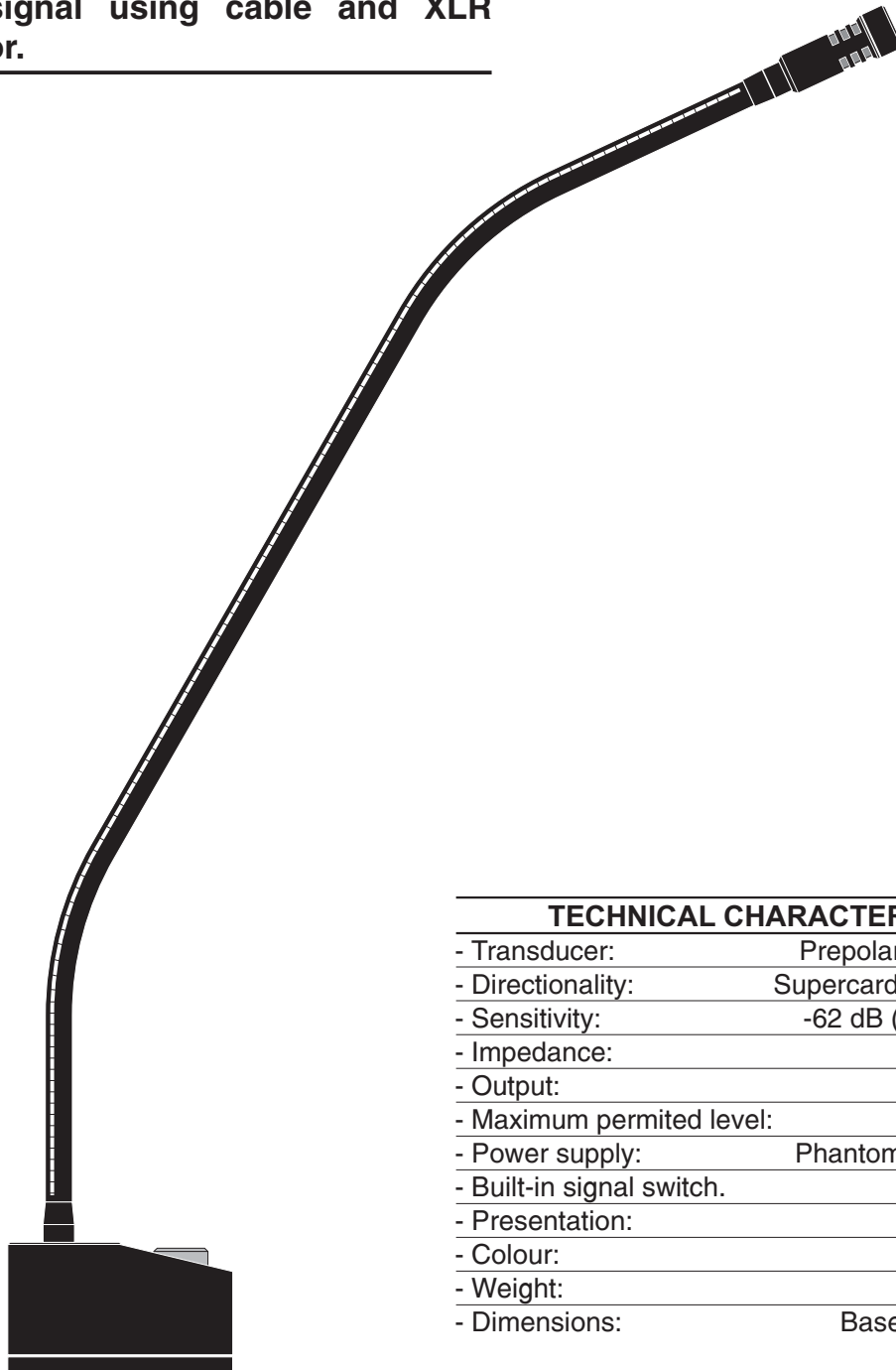

Universal presidential microphone, miniature, with flex and switch, balanced output signal using cable and XLR connector.



TECHNICAL CHARACTERISTICS

- Transducer:	Prepolarised condenser.
- Directionality:	Supercardioid (one-way).
- Sensitivity:	-62 dB (0 dB=1 V/ μ Bar).
- Impedance:	400 ohm.
- Output:	Balanced.
- Maximum permitted level:	115 dB NPS.
- Power supply:	Phantom (9 to 48 VDC.).
- Built-in signal switch.	
- Presentation:	Epoxy metal.
- Colour:	Black.
- Weight:	300 grammes.
- Dimensions:	Base = \varnothing 50x29 mm. Flex = 332 mm.

Electroacústica

 **UNION
DESARROLLOS
ELECTRONICOS s.a.**

www.udeaudio.com

Main Office Avda. BARCELONA, 24
08970 - SANT JOAN DESPÍ
BARCELONA - ESPAÑA
Tel: 34-93 477 28 54
Fax: 34-93 261 17 52
ude@udeaudio.com

Madrid Delegation C/ LUIS I, 88, 3ª planta
28031 - MADRID
ESPAÑA
Tel: 34-91 311 60 76
Fax: 34-91 450 19 97
centro@udeaudio.com

ISO 9001
BUREAU VERITAS
Certification



UDE reserves the right to modify the technical characteristics of its products without previous notice

610.011A | 1 / 2

DESCRIPTION

The CM-101 microphone includes one cell to a prepolarised condenser, and has been designed specifically for voice reproduction.

Its supercardioid polar diagram reduces environmental noise pick-up, thereby enhancing the speaker's voice. It also reduces acoustic coupling (Larsen effect). The result can be even further enhanced when used with a DM-1 Decoupler or a WX-19 diagram (anti-Larsen).

Its attractive streamlined and functional design makes it suitable for applications requiring a combination of aesthetic appeal, discretion and high-performance technology, such as:

- Conference halls
- Temples

- Administration, etc.

The CM-101 microphone has a built-in pre-amplifier which is remote-powered from the amplifier (Phantom power), which means it requires no batteries.

It is protected against external R.F. interference, electrostatic and magnetic fields.

Its output signal is balanced, allowing the use of a microphone with long cable lengths without any noise pick up or appreciable signal losses.

The CM-101 has an on/off switch.

It is supplied with a foam filter and case.

USE

Its modular design makes it universal for different applications, using the following accessories:

- **Desktop assembly:** Fit **WM-103** base (optional)
- **Fixed assembly on Lectern, Ambo or Table:** Adapter coupler **WM-104** (optional)
- **Assembly with telescopic stand:** Adapter coupler **WM-102** (optional)
- **Foam filter:** Should be used when the speaker is speaking close to the microphone.

OPTIONAL ACCESSORIES

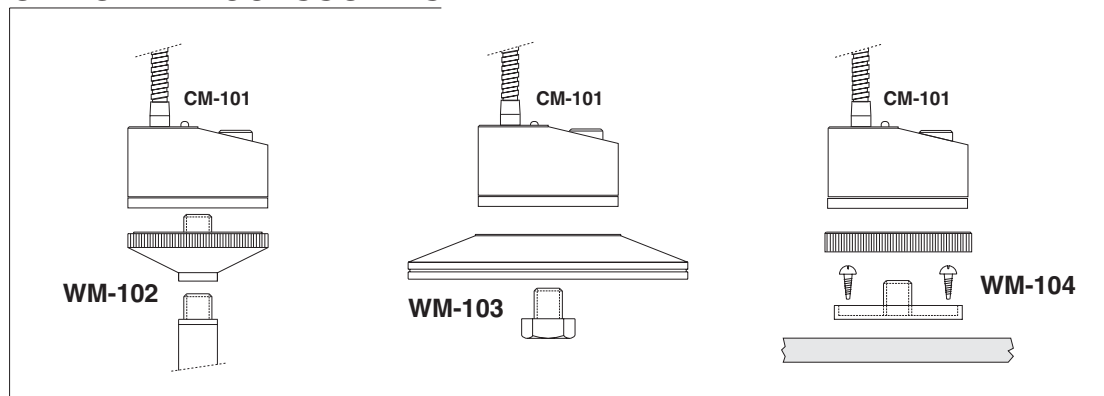

WIRING

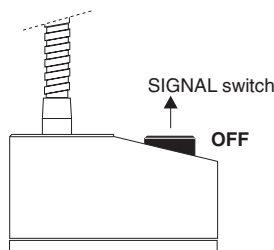
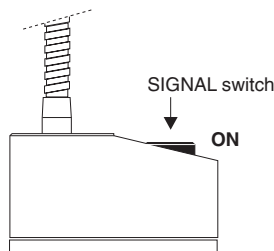

XLR CONNECTOR

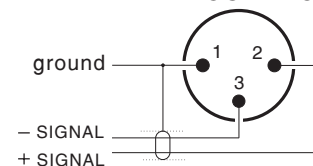

IMPORTANT:

- To connect the CM-101 microphone to a UDE apparatus, connect the programme jumpers for "Phantom" power. These are included inside the amplifier (AX-309, AX-209, AX-129, AX-59, AX-29, PX-9, PX-19).
- Please contact us for other makes and models.