

BP-25/25T

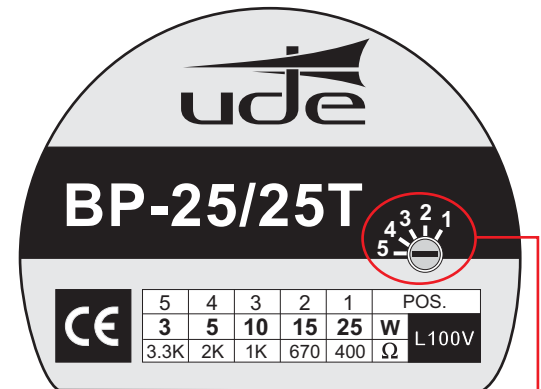

BOCINA EXPONENCIAL HAUT-PARLEUR A CHAMBRE DE COMPRESSION EXPONENTIAL HORN

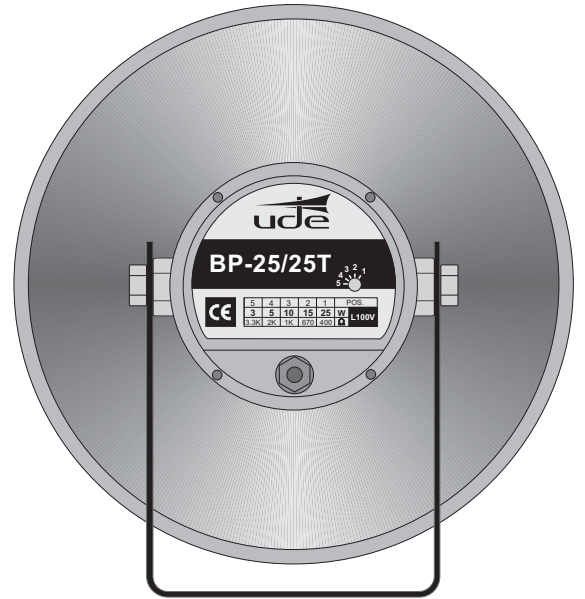
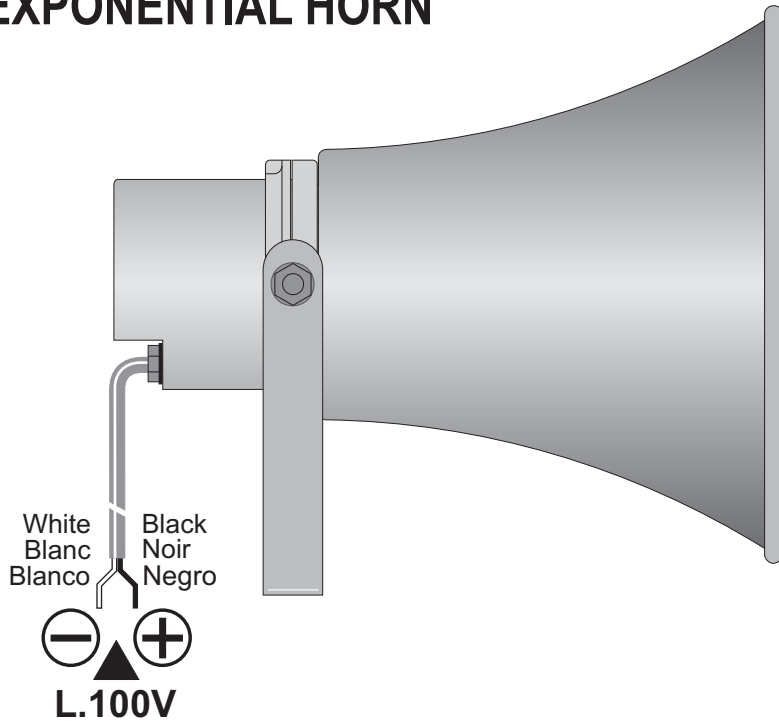

SELECTOR ROTATIVO DE POTENCIAS
SÉLECTEUR ROTATIF DE PUISSANCES
ROTARY SWITCH

CARACTERISTICAS TECNICAS	
- Potencia nominal:	25 Wrms.
- Sensibilidad (1W/1m/1kHz):	108 dB SPL.
- Banda pasante:	300 a 11000 Hz.
- Impedancia:	Transformador línea 100 V.
- Angulo apertura:	70°.
- Peso:	1.95 Kg.
- Color:	Gris.
- Selección de potencia (L100 V.):	25/15/10/5/3 W.

CARACTERISTIQUES TECHNIQUES	
- Puissance nominale:	25 Wrms.
- Rendement (1W/1m/1kHz):	108 dB SPL.
- Bande passante:	300 à 11000 Hz.
- Impédance:	Transformateur ligne 100 V.
- Angle d'ouverture:	70°.
- Poids:	1.95 Kg.
- Couleur:	Gris.
- Sélecteur de puissance (L 100 V.):	25/15/10/5/3 W.

TECHNICAL CHARACTERISTICS	
- Rated power:	25 Wrms.
- Sensitivity (1W/1m/1kHz):	108 dB SPL.
- Frequency range:	300 to 11000 Hz.
- Impedance:	Line transformer 100 V.
- Dispersion:	70°.
- Weight:	1.95 Kg.
- Colour:	Gray.
- Power selection (L 100 V.):	25/15/10/5/3 W.

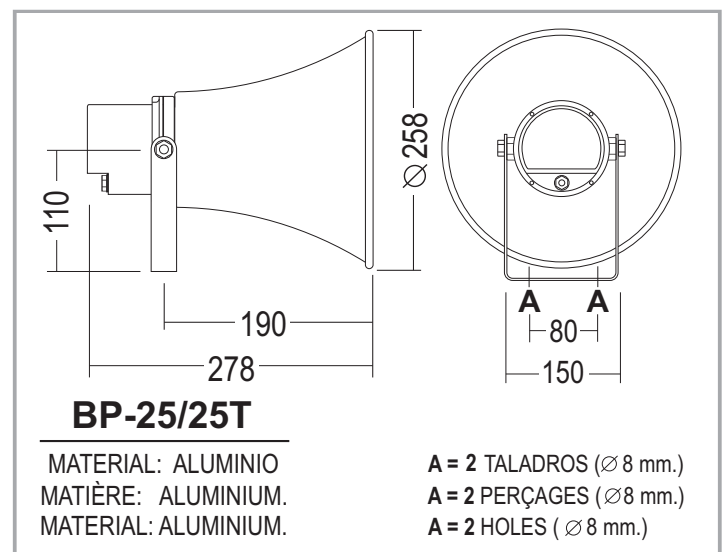

Electroacústica



www.udeaudio.com

Central Avda. BARCELONA, 24
08970 - SANT JOAN DESPÍ
BARCELONA - ESPAÑA
Tel: 34-93 477 28 54
Fax: 34-93 261 17 52
ude@udeaudio.com

Delegación C/ LUIS I, 88, 3ª planta
Madrid 28031 - MADRID
ESPAÑA
Tel: 34-91 311 60 76
Fax: 34-91 450 19 97
centro@udeaudio.com

ISO 9001
BUREAU VERITAS
Certification



Se reserva el derecho de variar las características técnicas de sus productos sin previo aviso

610.391CFA | 1 / 1