

AX-121MP

AMPLIFICADOR MEZCLADOR CON REPRODUCTOR MP3

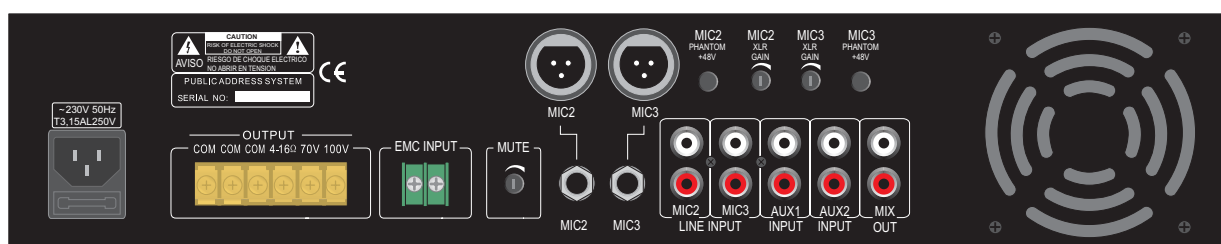

DESCRIPTION

120 W mixer amplifier RMS with low impedance exit of 4 to 16 ohms and line of 70V and 100V, for professional audio applications.

Versatile amplifier with MP3 player integrated. Can be used in many places as well as schools, hotels, entertainment...

The MP3 integrated reader allows the music diffusion, recorded announcements, advertisements, as well as many other uses.

The amplifier **AX-121MP** has asymmetric microphone input, 2 balanced microphone inputs / asymmetric microphone / asymmetric line, 2 auxiliary inputs, 1 emergency input and 1 output signal of 0 dB.

The MIC 2 and MIC 3 inputs (conector XLR) has "phantom" alimentation, specially for the electret microphone.

General volume control and independent volume controls for the microphone and auxiliaries inputs.

Baxandall tone control with independent controls for bass and treble.

Vumeter modulation indicator.

Electronic protection against short circuits and for over temperature.

TECHNICAL CHARACTERISTICS

- Power (RMS):	120 W.	- 1 MICRO input symmetric (5 mV / 600 Ω):	MIC 1 (JACK - symmetric).
- Speakers outputs:	4-16 Ω , L70V, L100V.	- 2 MICRO inputs (5 mV-250 mV / 600 Ω) / LINE (775mV / 10K Ω):	MIC 2 (XLR/JACK - symmetric with phantom 48V.) / LINE 2 (JACK - symmetric)
- Distortion:	Below 1%.		MIC 3 (XLR/JACK - symmetric with phantom 48V.) / LINE 3 (JACK - symmetric)
- Passant band:	50 Hz. to 15 Khz. (+/-2dB).	Note 1:	<i>The inputs MIC 2 and MIC 3 had each one, and independent volume in the front panel. In this inputs you can use either the connection balanced microphone (XLR), asymmetric microphone (JACK) or asymmetric line microphone (RCA) but not the 3 at the same time.</i>
- Tone control:	Bass: 100 Hz. \pm 10 dB. Treble: 10 KHz. \pm 10 dB.	- 2 AUXILIARY inputs (350 mV / 10K Ω):	AUX 1 (2xRCA - asymmetric). AUX 2 (2xRCA - asymmetric).
- Crosstalk:	Mic: 80 dB. / Aux: 85 dB.	- 1 EMERGENCY input (750 mV / 10K Ω):	EMC (terminal strip - asymmetric).
- Signal - noise ratio:	Mic 1, 2, 3: 66 dB. Aux 1, 2: 80 dB.	- 1 OUTPUT signal (775mV):	MIX OUT (2xRCA - asymmetric).
- Energy supply:	230 VAC (50/60 Hz).		
- Maximum consumption:	200 W.		
- Dimensions:	484 x 88 x 353 mm. (2 U).		
- Weight:	10,2 Kgs.		

PRIORITIES: MIC 1 over the rest of the inputs, for audio level activation (VOX) MUTE adjustment (0 to 30 dB)
EMC on the other inputs (except to MIC1)

Electroacústica

ude
UNION
DESARROLLOS
ELECTRONICOS S.a.

www.udeaudio.com

Main Office Avda. BARCELONA, 24
08970 - SANT JOAN DESPÍ
BARCELONA - ESPAÑA
Tel: 34-93 477 28 54
Fax: 34-93 261 17 52
ude@udeaudio.com

Madrid Delegation C/ LUIS 1, 88, 3ª planta
28031 - MADRID
ESPAÑA
Tel: 34-91 311 60 76
Fax: 34-91 450 19 97
centro@udeaudio.com

ISO 9001
BUREAU VERITAS
Certification



UDE reserves the right to modify the technical characteristics of its products without previous notice

610.426A | 1 / 2

FRONT PANEL

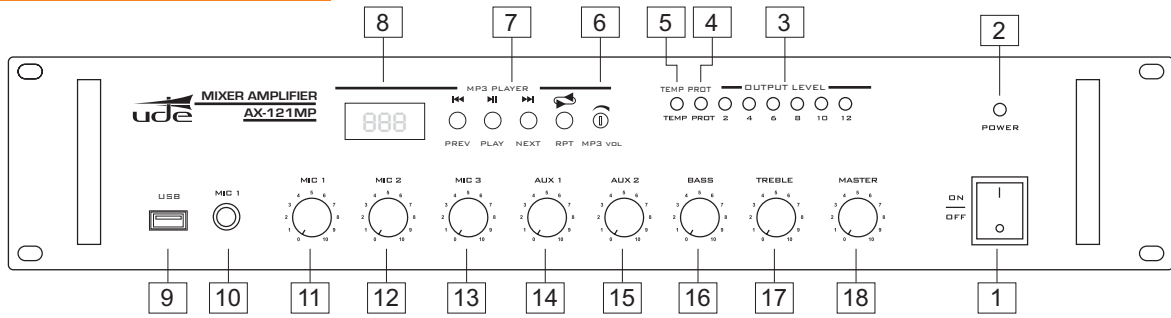

- | | | | |
|-------------------------|----------------------------|-------------------|-------------------------|
| 1 - Start switch. | 6 - Vol. MP3 | 11 - Vol. Micro 1 | 16 - Bass adjustment. |
| 2 - On pilot. | 7 - MP3 player functions | 12 - Vol. Micro 2 | 17 - Treble adjustment. |
| 3 - Vumeter modulation. | 8 - MP3 display | 13 - Vol. Micro 3 | 18 - Vol. Master |
| 4 - Protection pilot. | 9 - USB | 14 - Vol. Aux 1 | |
| 5 - Temperature pilot. | 10 - Micro 1 (Jack) input. | 15 - Vol. Aux 2 | |

REAR PANEL

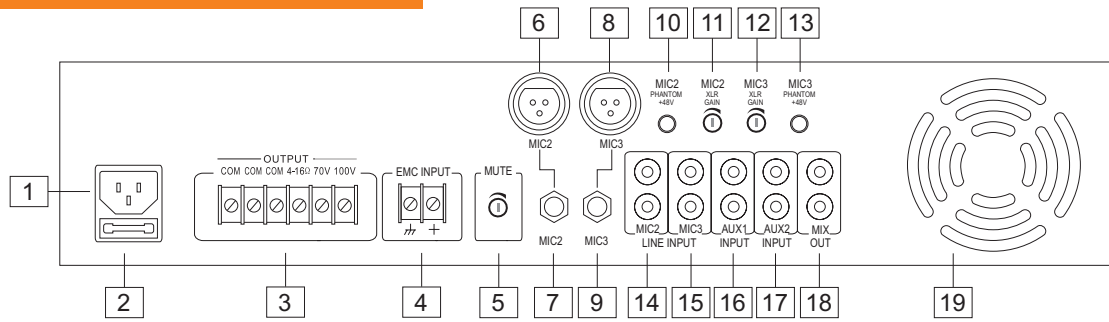

- | | |
|---|--|
| 1 - Energy input (230 VAC) | 11 - Gain setting - Mic 2 (XLR) |
| 2 - AC Fuse - T3,15A | 12 - Gain setting - Mic 3 (XLR) |
| 3 - Speaker output (4-16Ω / L100V-L70,7V.) | 13 - Phantom selector - Micro 3 |
| 4 - EMC asymmetric input | 14 - Line Micro 2 (RCA) input asymmetric - see note 1. |
| 5 - MUTE. Attenuation adjustment, priority Mic 1 | 15 - Line Micro 3 (RCA) input asymmetric - see note 1. |
| 6 - Micro 2 (XLR) input symmetric - see note 1. | 16 - Aux 2 (RCA) input asymmetric |
| 7 - Micro 2 (Jack) input asymmetric - see note 1. | 17 - Aux 3 (RCA) input asymmetric |
| 8 - Micro 3 (XLR) input symmetric - see note 1. | 18 - Signal output asymmetric 0 dBm. (RCA) |
| 9 - Micro 3 (Jack) input asymmetric - see note 1. | 19 - Ventilation grille |
| 10 - Phantom selector - Micro 2 | |

REMOTE CONTROL MP3 PLAYER

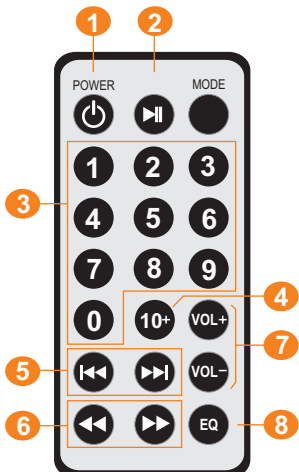

- | |
|------------------------------|
| 1 - STANDBY / ON MP3 PLAYER |
| 2 - PLAY / PAUSE |
| 3 - TRACK NUMBER |
| 4 - FORWARD TEN TRACKS (+10) |
| 5 - PREV / NEXT |
| 6 - REW / FAST FORWARD |
| 7 - VOL (-) / VOL (+). |
| 8 - SOUND EFFECT CONTROL |

CONNEXIONS CONNECTORS

